

DMX Address Editor Operation Instructions



I, Specifications:

Working temperature: -20~60 °C

Supply voltage: DC12V

Dimensions: L224×W128×H37mm

Function: Revise the address (ID value) of DMX receiving module

II, Control Method:

Buttons control mode, function of each button explains as follows:

“Inquire”: Inquire the ID value of Receiving Module

“Send”: Send revised ID values to Receiving Module

“▲” : ID value added by one

“▼” : ID value reduced by one

III, Operation Procedure:

Connect DMX Receiving Module and Address Editor with signal cable, power on them, screen displays “DMX512 Editor ” ; Then you can operate according to following two methods:

①Press " ▲ 、 ▼" to revise the ID value. Screen displays present ID value in both the decimal system and the binary system, for example: " Device ID: 0001 Bin: 00000000001 ". After finished revising the ID value, press "Send", screen displays “Sending ... ”, If send successfully, screen displays "Sending OK!"

②Press “Inquire”, screen displays “Looking Up ...”, If inquire successfully, Screen displays ID value of the DMX Receiving Module, then you can continue operating following step ①.

If screen displays "Error" when presses "Inquire" Or "send", Please check separately:

- A. If signal cable are poor connected or damaged;
- B. If Module is power on;
- C. Whether DMX Master is out of power or Receiving Module is disconnected from the Master;

If there is any communication problems that are not caused by above reasons, please contact us freely!

IV. For your information:

- 1 Supported revising ID Value range: 1~1022;
- 2. Temporarily we could only support revising or inquiring one receiving module at a time;
- 3. There is a male and a female signal ports on the Address Editor, they are all signal ports, but fits for different signal wires with different plugs.

V. Safety Information:

- 1. Supply voltage of this product is DC12V; never connect to DC24V or other voltage;
- 2. Warranty of this product is one year, in this period we guarantee replacement or repairing with no charge, but exclude the artificial damage or overload working.

VI. Explanatory Graph:

Panel Board:

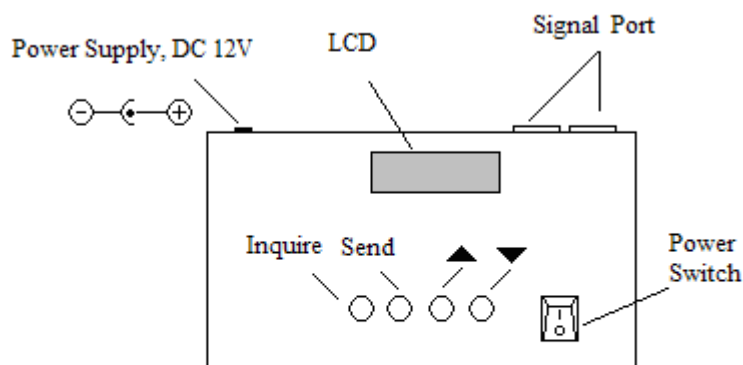

Signal Port Local Illustration:

